

Right Connections

towbar wiring kits for the uk

V-Class W447	06/2014 >>
V-Class EQV W447	10/2020 >>
Vito W447	11/2014 >>
eVito W447	2019 >>
eVito Tourer W447	2019 >>

Part No: MB-090-13

Electric wiring kit for towbars / 13-pin / 12 Volt / ISO 11446 Fitting instructions

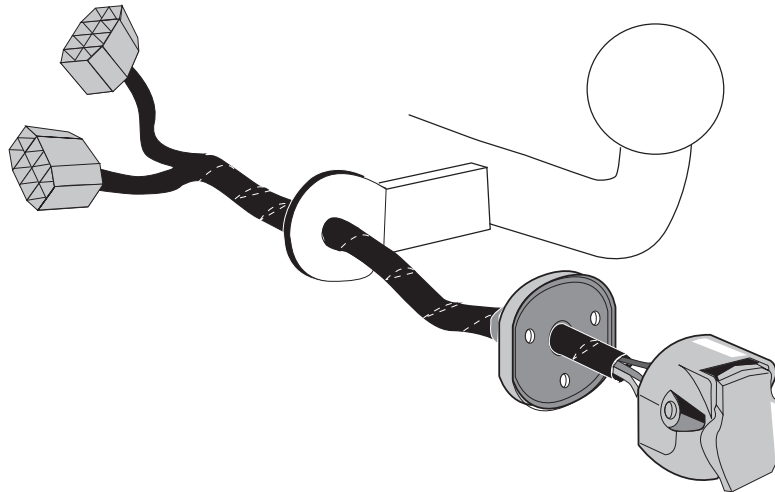

IMPORTANT!

This electric kit has to be installed by a professional workshop or a suitable qualified person.

The installation instructions must have been read and fully understood before the start of any installation. Please contact your wiring kit provider or the hotline shown in the footer should you need assistance!

Make sure the vehicle is approved/homologated by the manufacturer to tow a trailer!

Also please check that there is a definite compatibility between this vehicle and the electric kit!

Following the installation of the electric kit, the fitting instructions should be kept together with the vehicle service document and vehicle handbook. The fitting instructions contain important information relating to the use and function of the towing kit as well as for any diagnostic or activation process, that might have to be repeated in the future (e.g. after the performance of a vehicle software update).

All warranty claims will be forfeited if the electric kit or components contained therein are used incorrectly or modified. If a towing socket adaptor has been used to connect to the trailer or bike rack, this must be removed from the trailer socket once the trailer or bike rack has been disconnected.

If the trailer or bike rack is not equipped with a rear fog lamp, depending on the towing vehicle type, the correct function of the towing kit cannot be guaranteed. In such cases, a rear fog lamp should be retro fitted.

This towing electric kit will not be covered under warranty if any technical or electrical modifications or software updates have been performed by the vehicle manufacturer after the initial commissioning of the kit. That applies especially to modifications or updates which may cause malfunctions in the trailer socket or any other part of the trailer electrical equipment!

Depending on the type of trailer module used in this electric kit, diagnostic interrogation with the vehicle's electrical system may be limited or will not function. The error memory inside the trailer module may not be able to be accessed by vehicle manufacturers diagnostic system.

Error logs relating to the trailer electrical equipment, that may be generated in the vehicle manufacturers diagnostic system as a result of a test procedure, may be due to the incorrect installation of the towing electric kit or the false activation of the trailer module.

We always recommend whenever possible, the following troubleshooting process:

→ **An analysis of the vehicle's error memory and possibly clearing of all faults before the start of the installation!**

→ **Try disconnecting the trailer module from the towing harness and re-start the fault clearing process!**

→ **If in doubt, limit the time for troubleshooting to a max of 0,5 hours and call our Technical Support Team!**

Please follow our instructions carefully and always test the towing electrics using a true lighting board or a specifically designed bulb tester. If an LED tester is used, ensure it is equipped with correct load resistors or malfunctions will occur!

This instruction is subject to changes and we reserve the right to make changes to design, colour etc.

All of the data and illustrations may not be an exact representation but the text contained in this instruction must be observed!

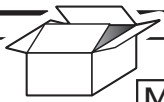

R1

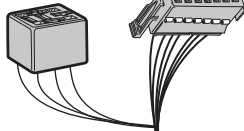

M

R

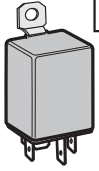

U

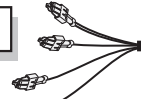

L



GND

X

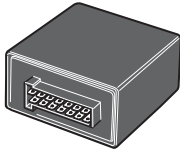
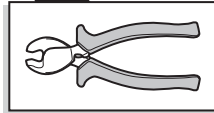

M

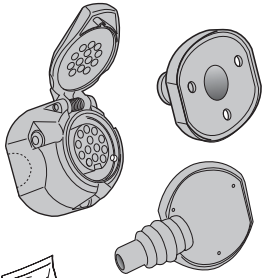

10x

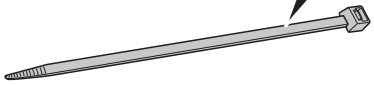

3x

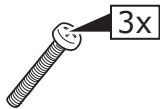

3x



3x

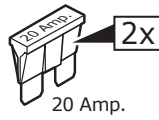

20 Amp.



5 Amp.

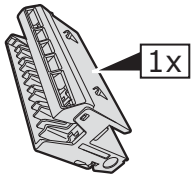

1x

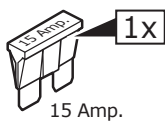

15 Amp.



2x

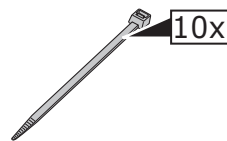

10x

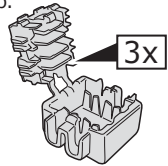

3x

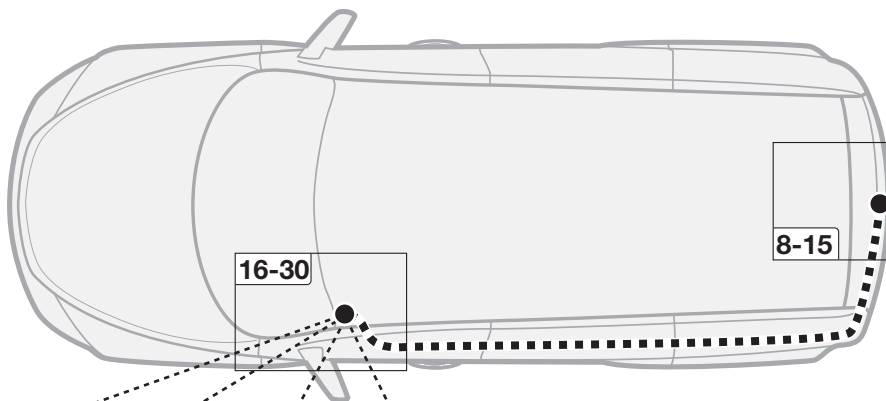

16-30

8-15

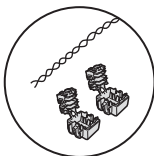
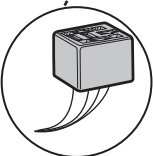
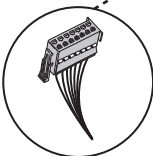
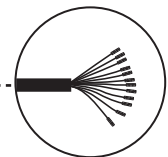

SYMBOL EXPLANATION

	Left (58-L) respectively Right (58-R) tail light
54	Stop light (54) / high mounted, third stop light (54)
	Turn signal indicator left
	Turn signal indicator right
	Rear fog light(s)
	Reversing light(s)
	Permanent power supply / 13pin socket, chamber 9
	Charging wire for trailer battery / 13pin socket, chamber 10
	Trailer / trailer recognition
B+ / 30	Permanent current power supply
	Ground or Earth (31)
	Ground connection battery terminal lug
	Positive connection battery terminal lug

	Cigarette lighter / accessory socket
	Loudspeaker / buzzer
	Park Distance Control
	Switch / source of function
	Connect together
	Disconnect
	Look at / See further information
	Look carefully at selected area
	Present / Occupied / OK
	Not present / Not occupied / Not OK
	Acoustic indication
	Attention / important advice
	Fuse / fuse capacity 20 Ampère

TOOLS

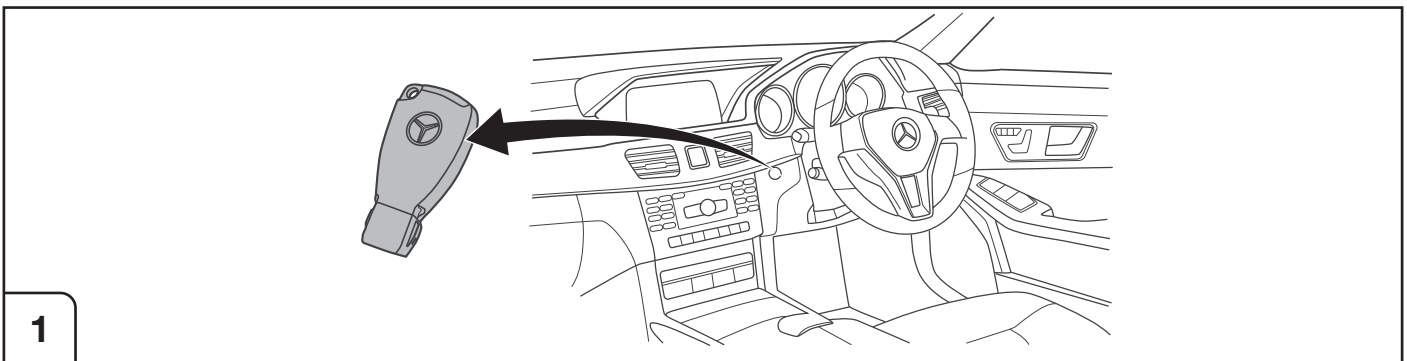
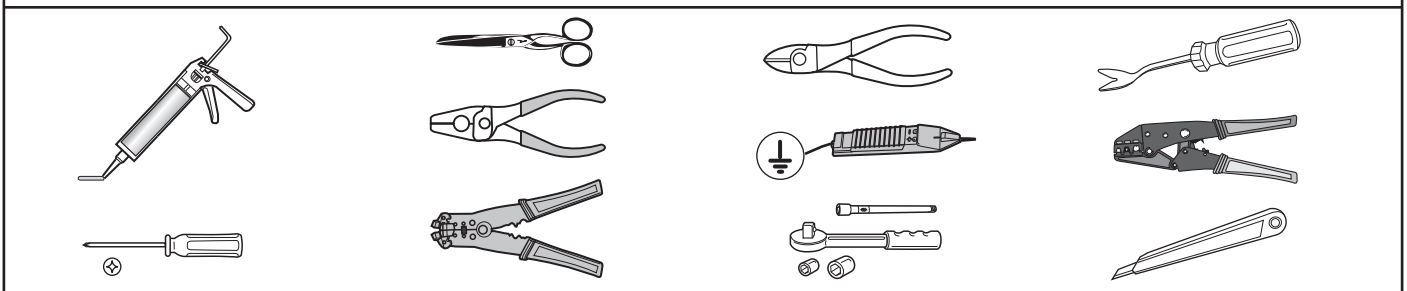

1

Keyless-go

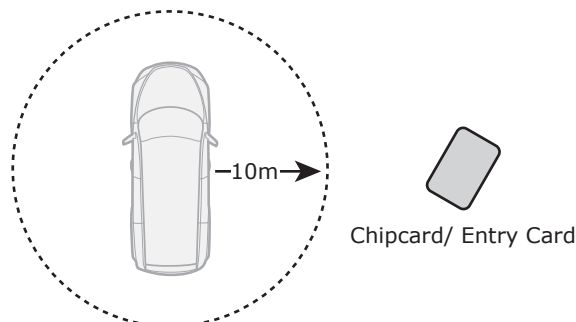

2

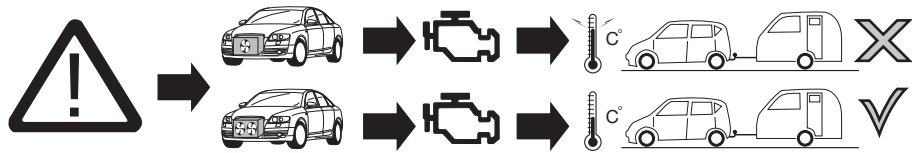

ATTENTION!

The vehicle's cooling capacity may have to be increased when retrofitting a trailer coupling!
You must observe the manufacturer's instructions!!

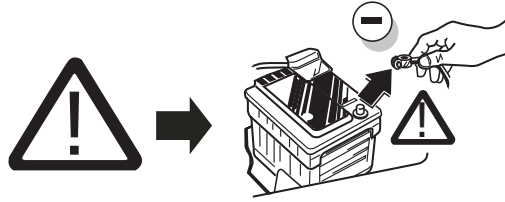

Note: It may be necessary to check if this vehicle has a stored radio code before disconnecting the battery!



ATTENTION!

In order to avoid mal-functions and damage to the vehicle's electrical system the earth terminal **must be disconnected** from the vehicle's battery **before starting work!**

Both the trailer module and the vehicle's control unit for the electrical system can be damaged during work on the data bus connections if the battery is not disconnected!

3

Please pay attention to the manufacturer's instructions when disconnecting and reconnecting the vehicle's battery!

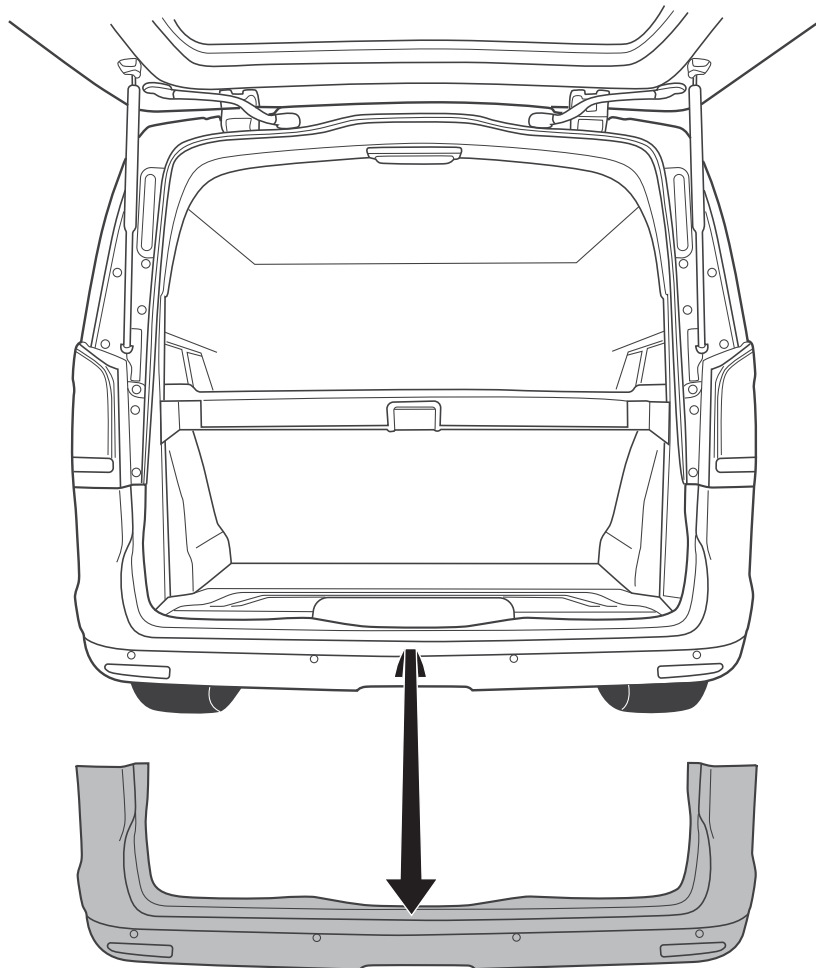

4

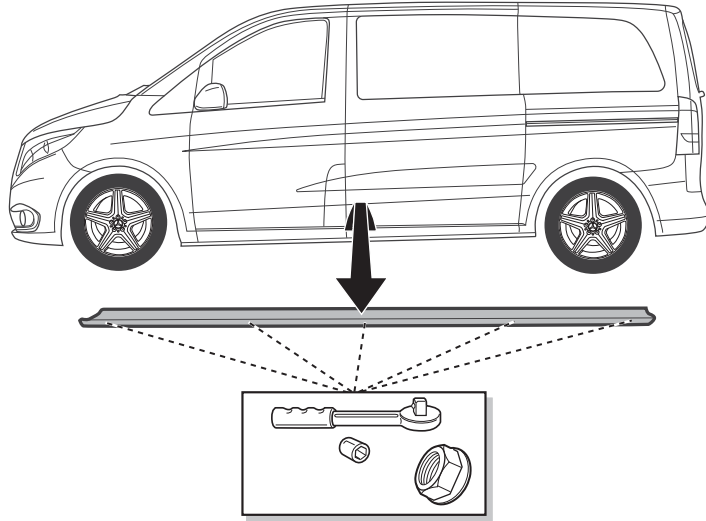

5

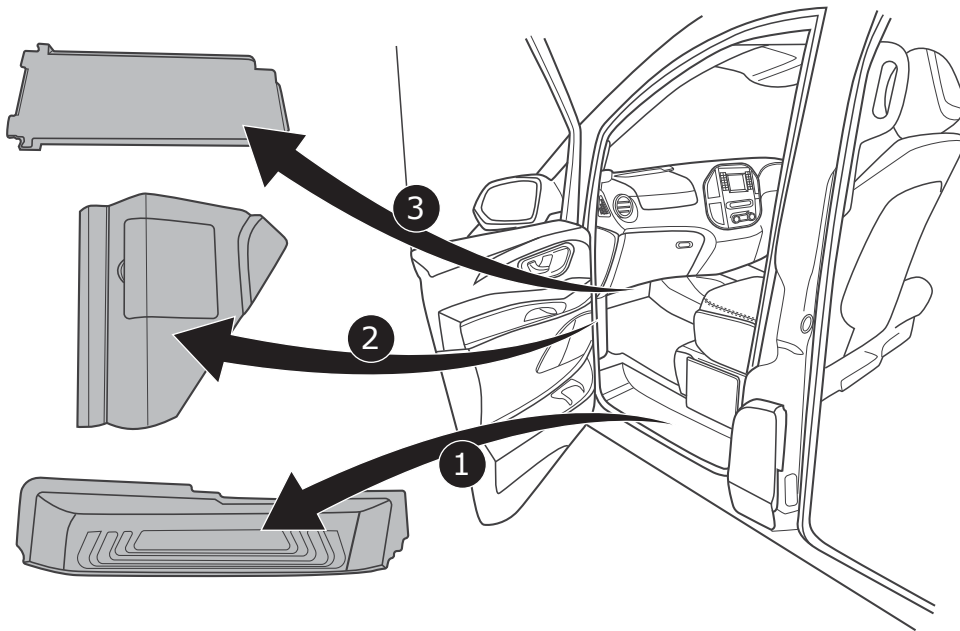

6

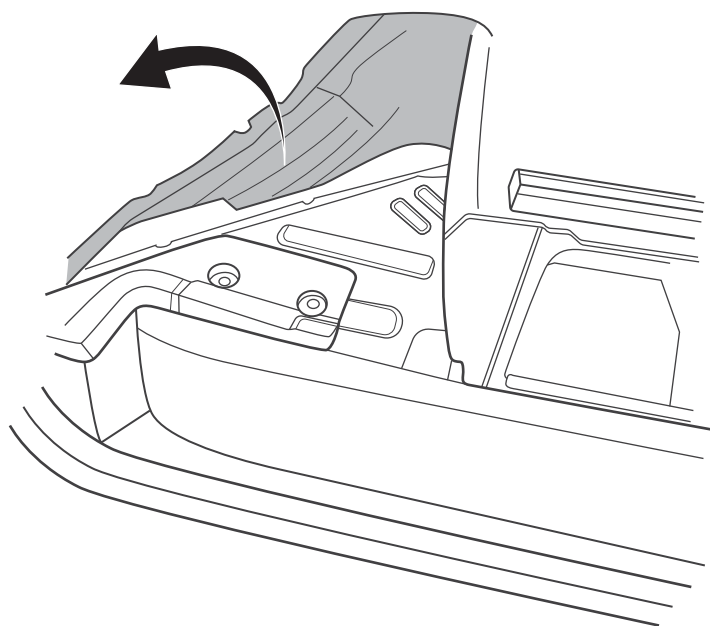
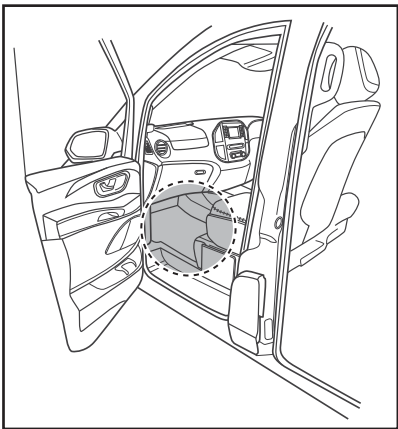
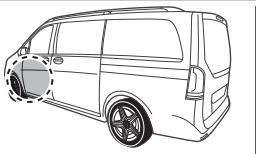

7

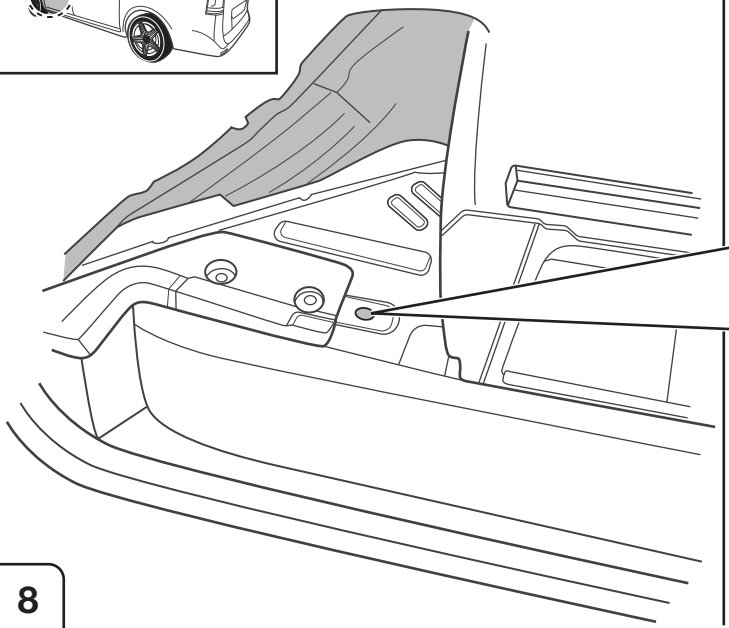

8

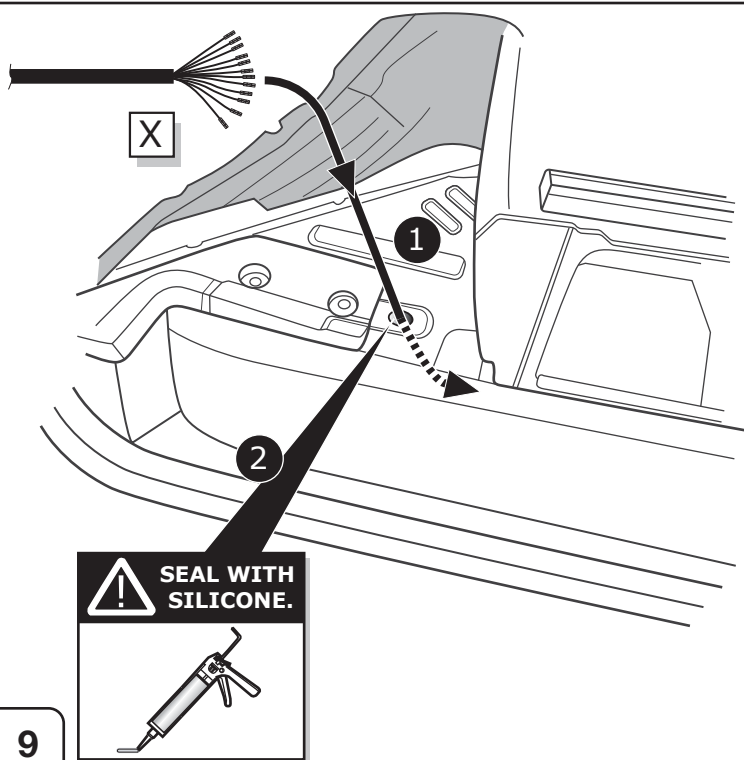
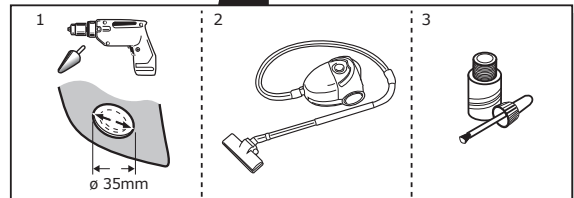
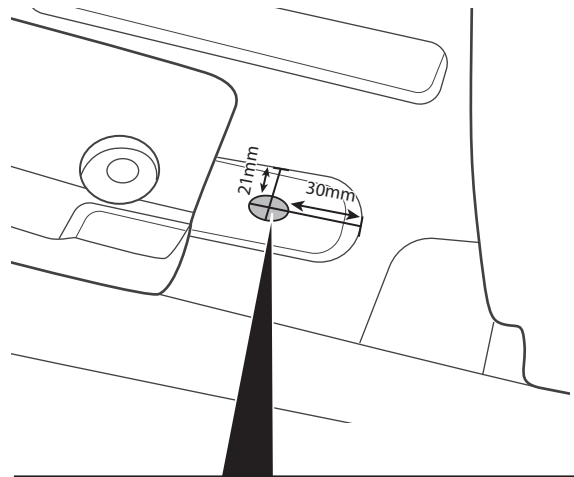

9

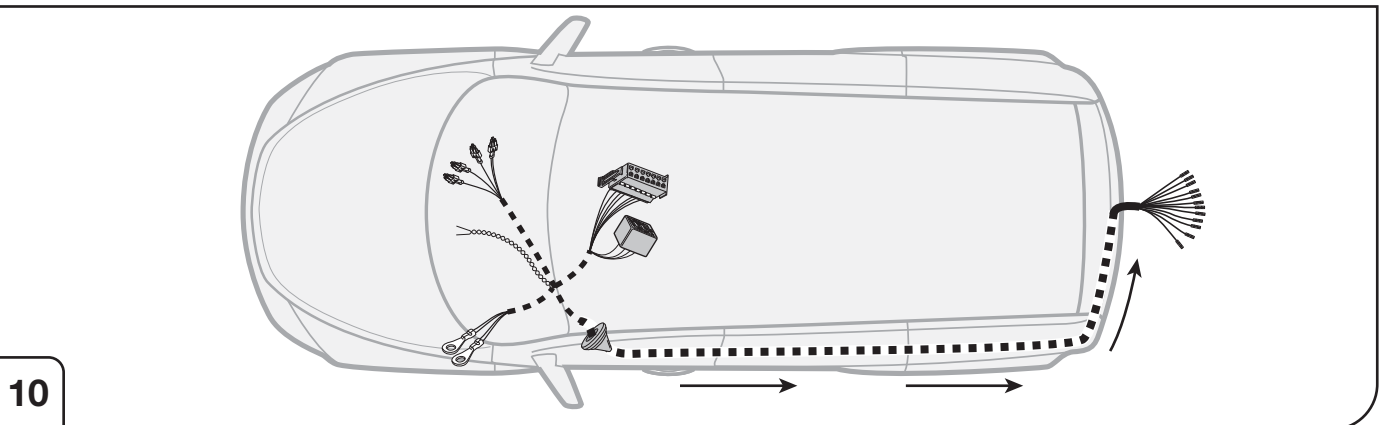
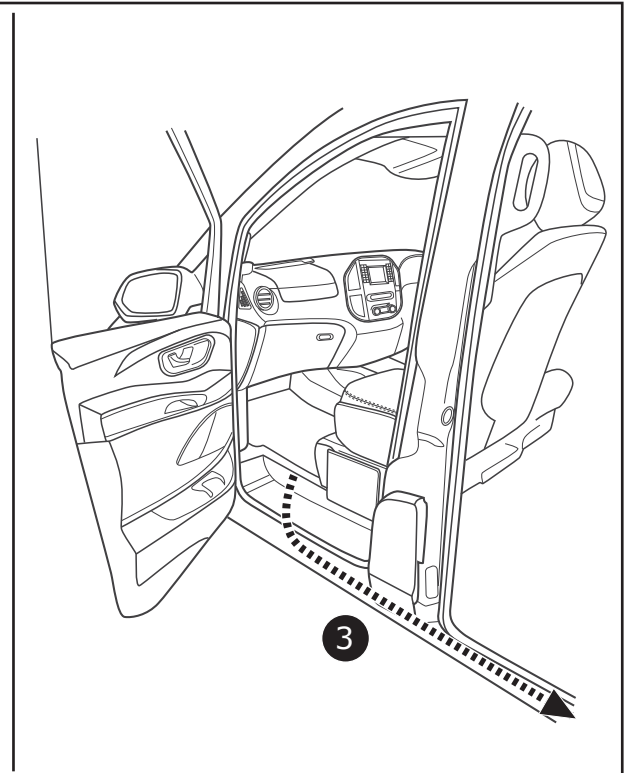

10

Option 1

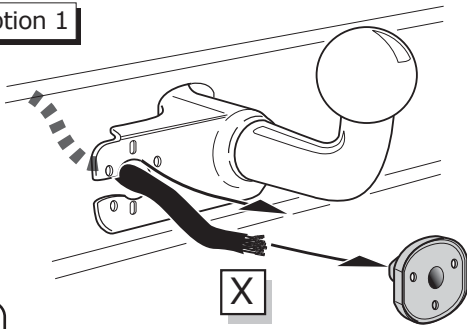

11

Option 2

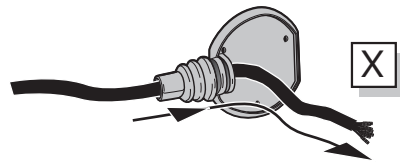

Option 3

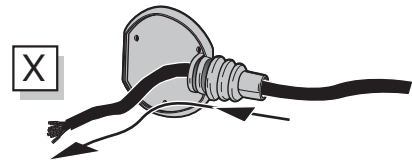

SOCKET CONNECTION



Page 19

12

Option 1

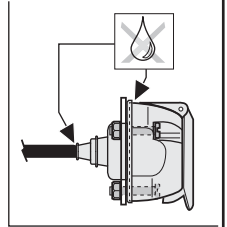
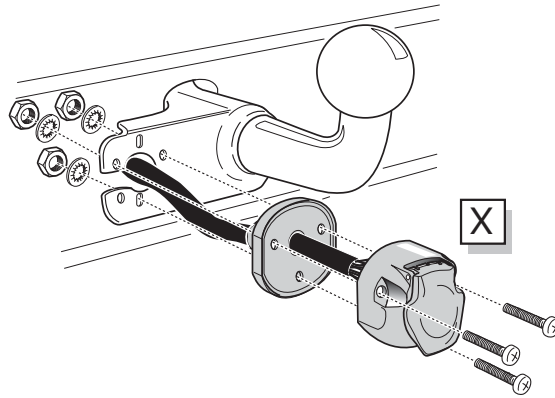

13

Option 2

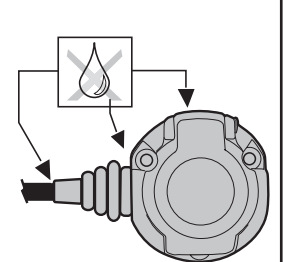
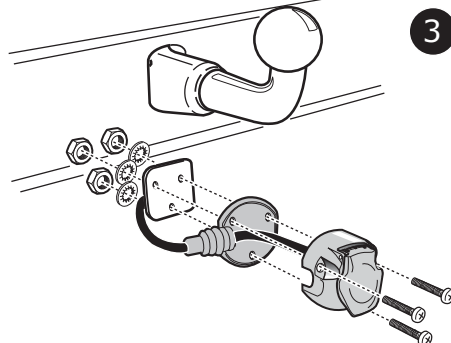
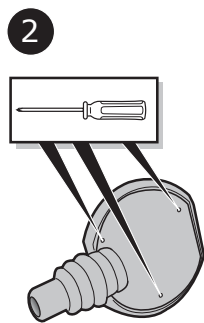
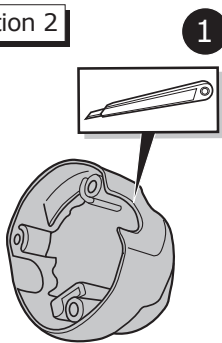

14

Option 3

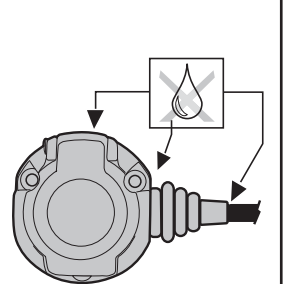
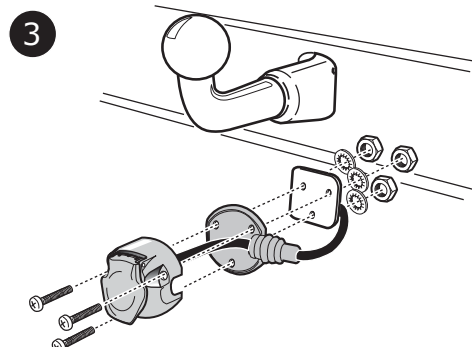
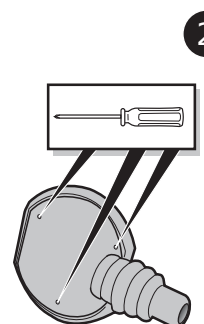
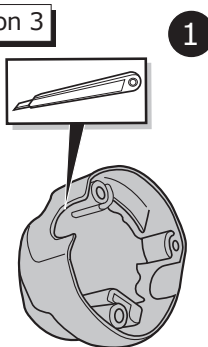

15

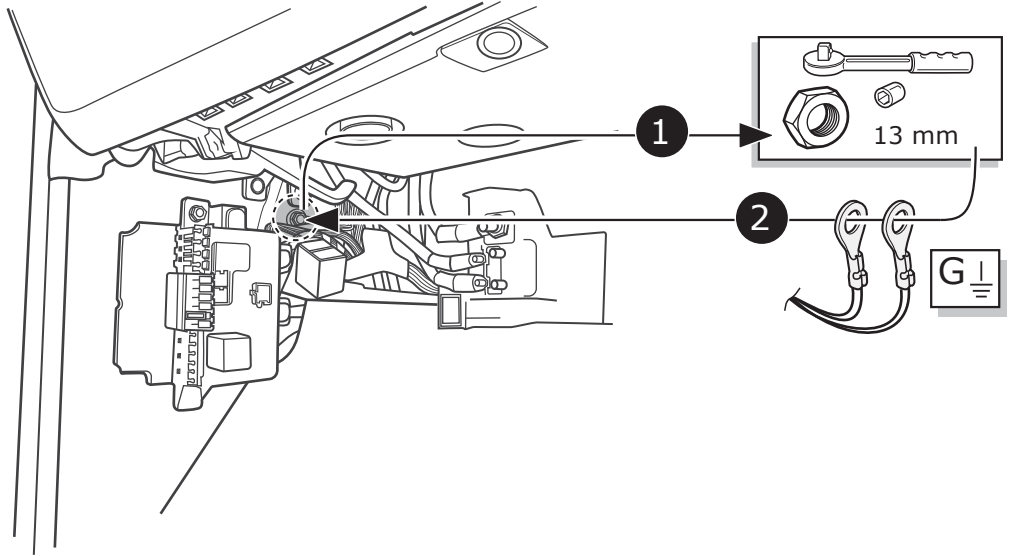

16

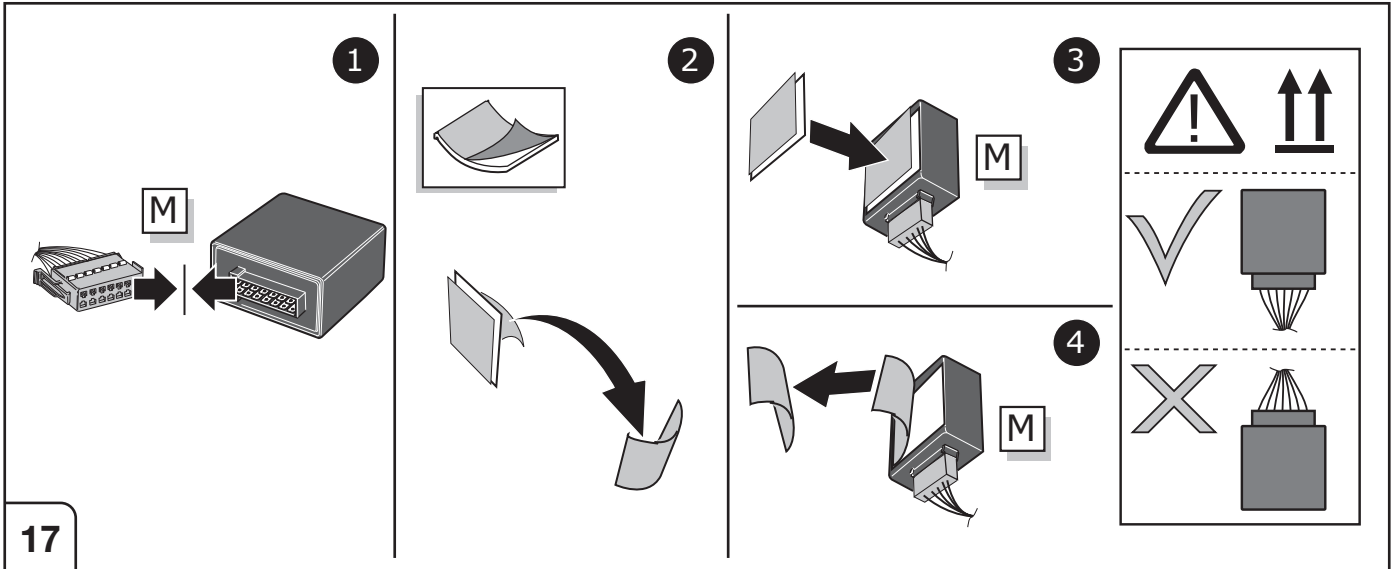

17

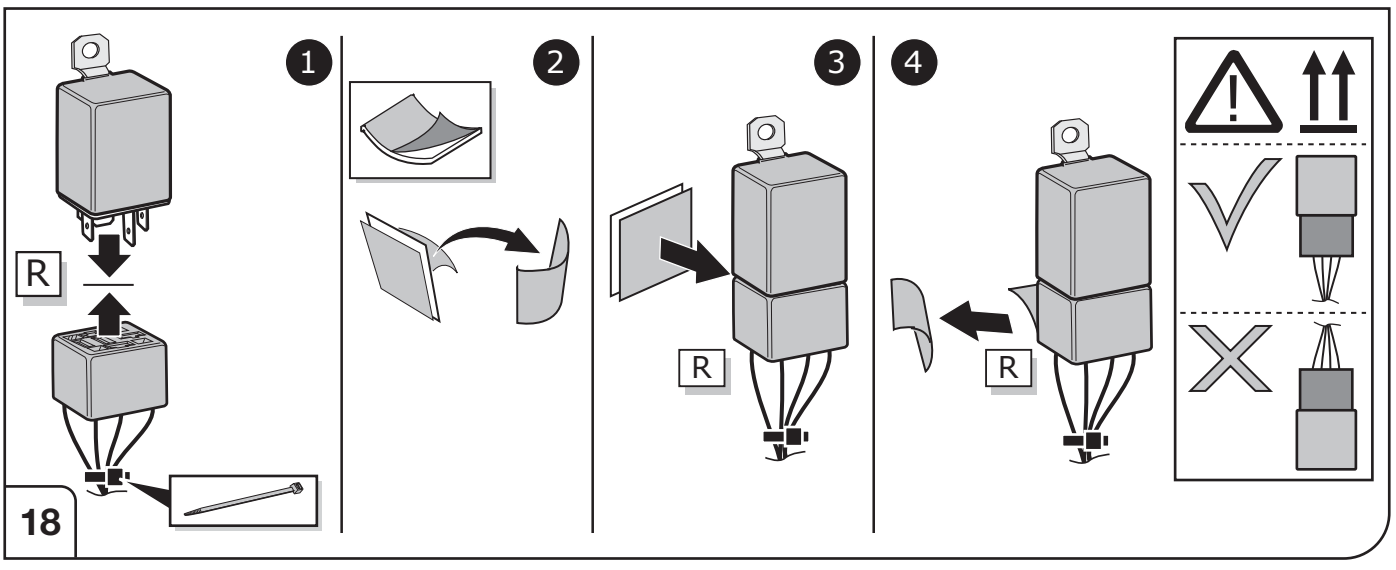

18

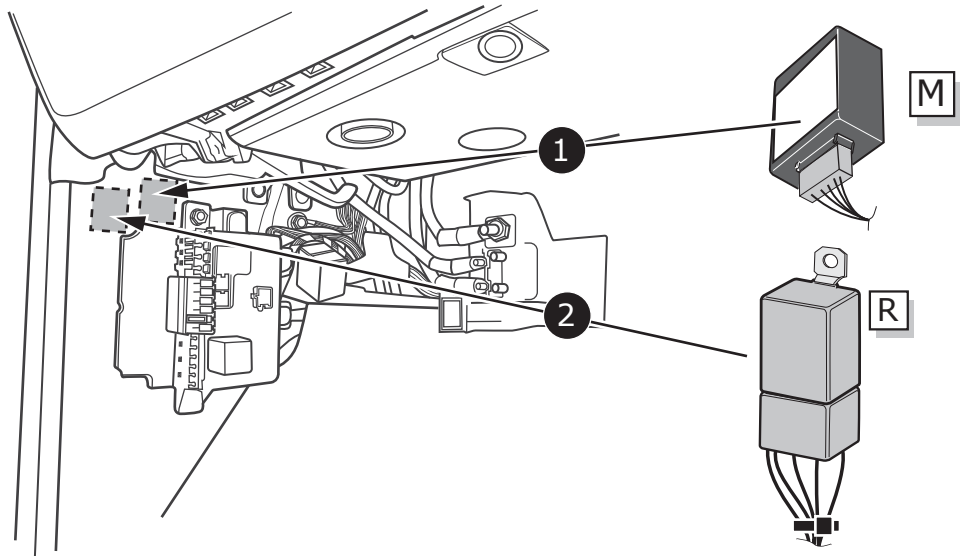
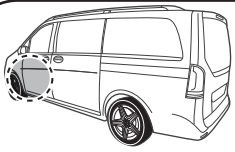

19

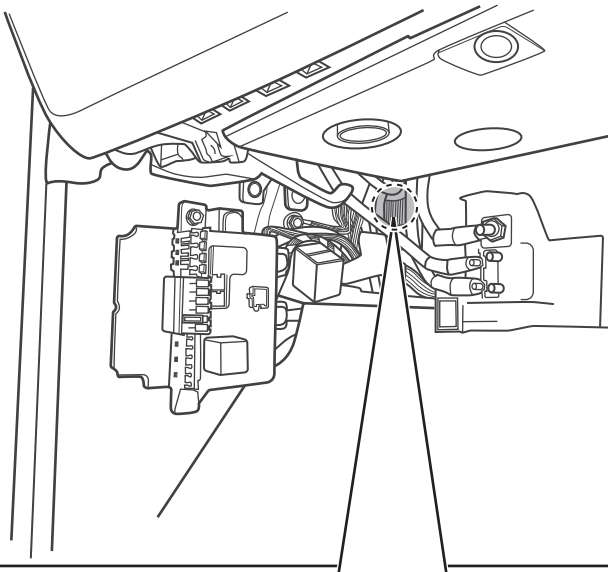
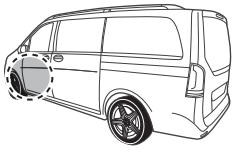

CAN-Data Wire

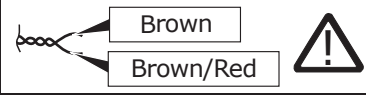

! Important!
Please note informations
in picture 3!

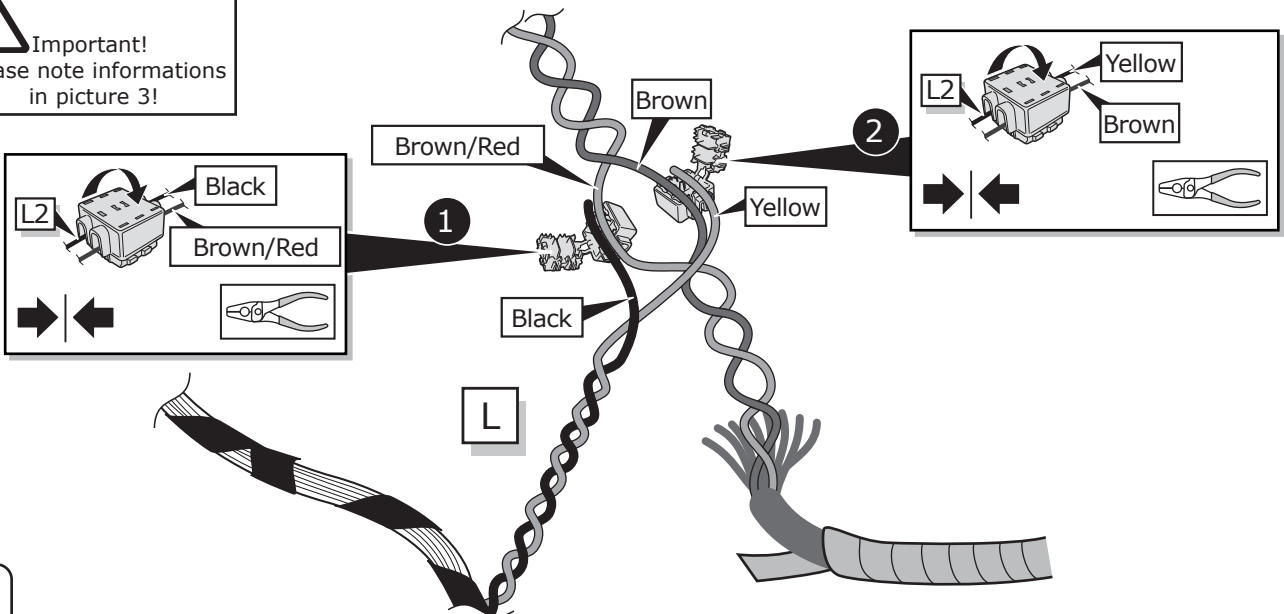

20

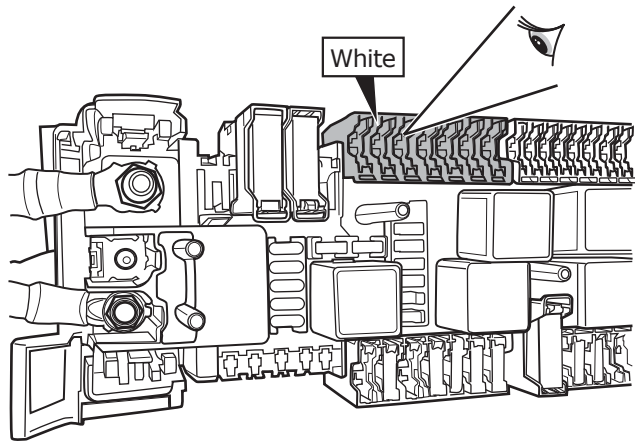

21

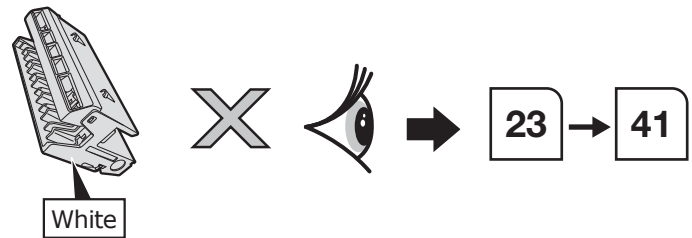
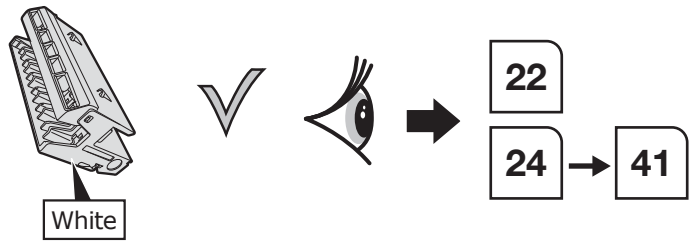

22

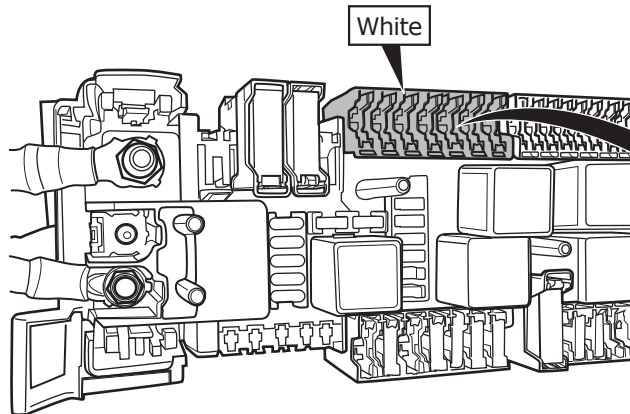

1

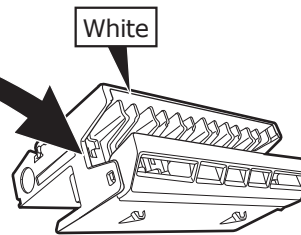

2

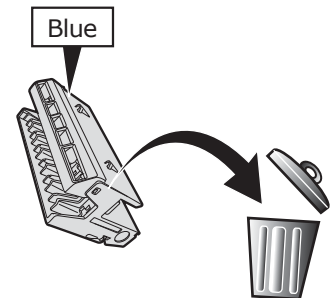

23

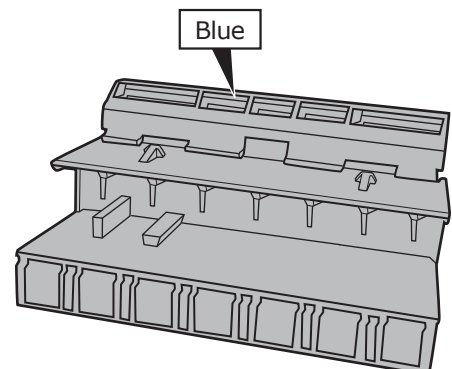
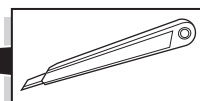
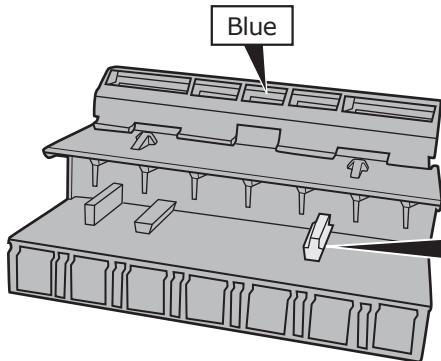

Open secondary lock!

1

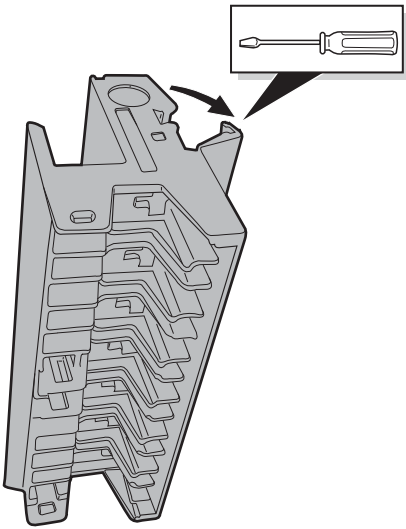

24



Chamber 75	→ ←	Orange
Chamber 76	→ ←	Red/Blue
Chamber 77	→ ←	Red/Yellow

2

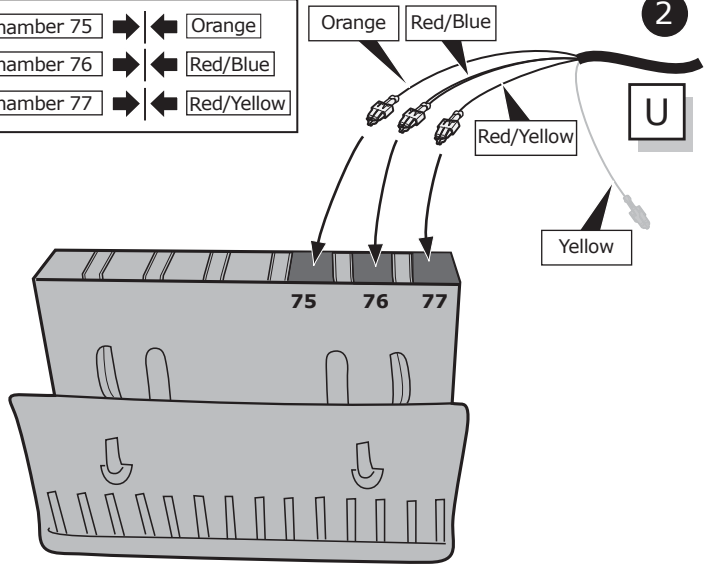

Close secondary lock!

1

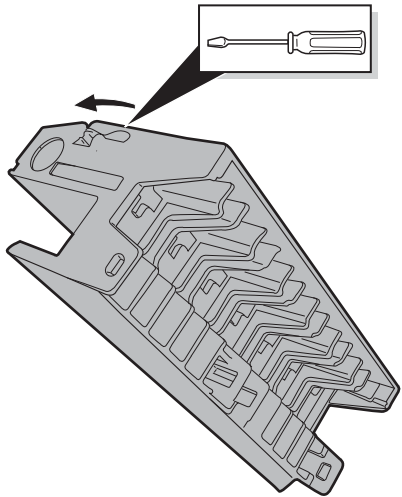

25

2

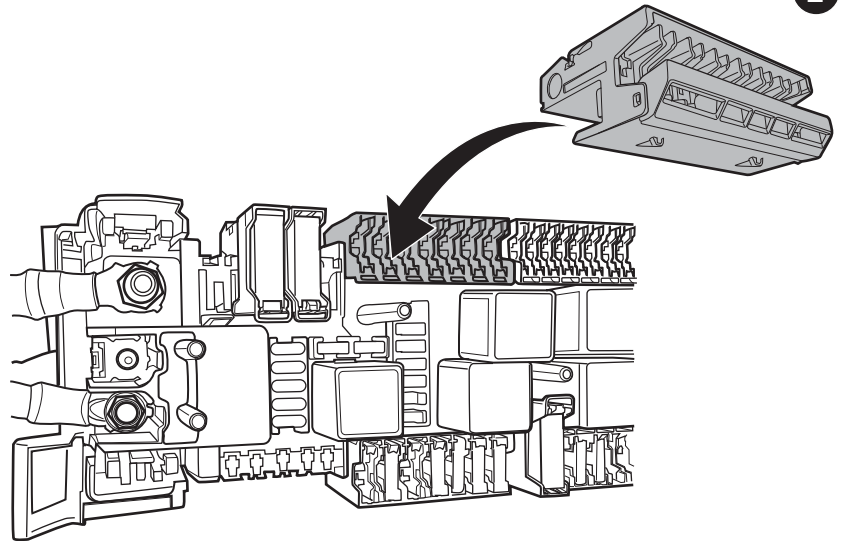

	20 Amp.
Red/Blue	Chamber 76
	20 Amp.
Orange	Chamber 75
	15 Amp.
Red/Yellow	Chamber 77

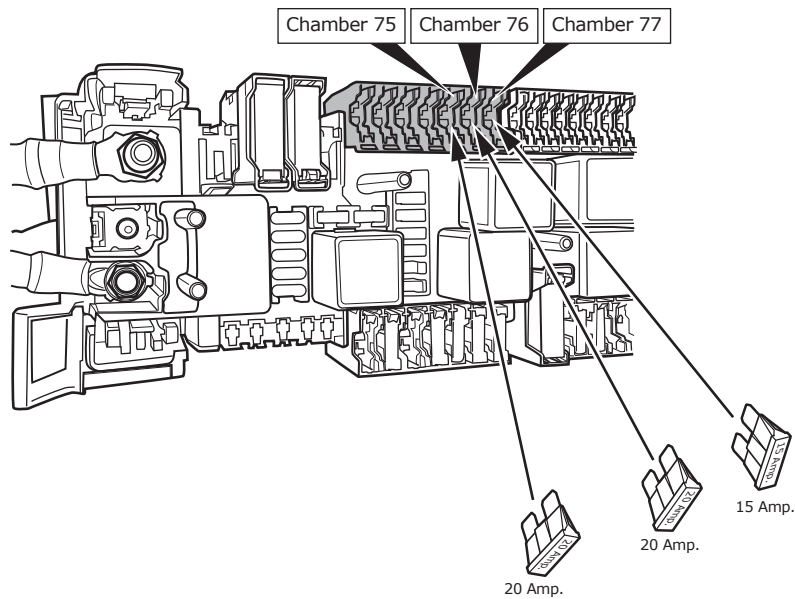

26

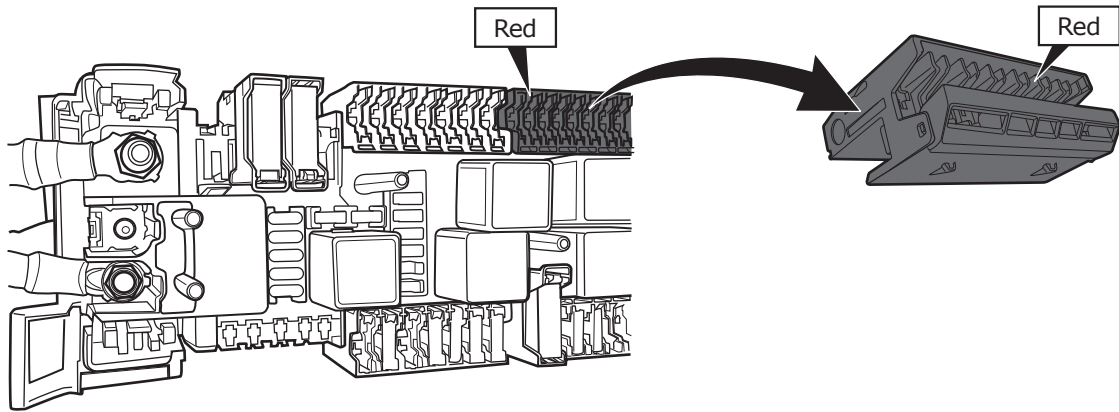

27

Open secondary lock!

1

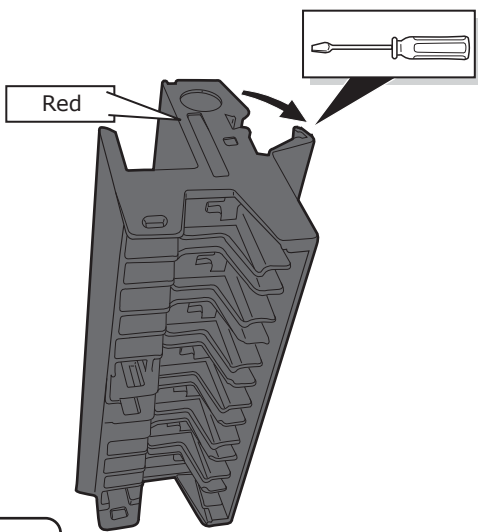

28



Chamber 70



Yellow

2

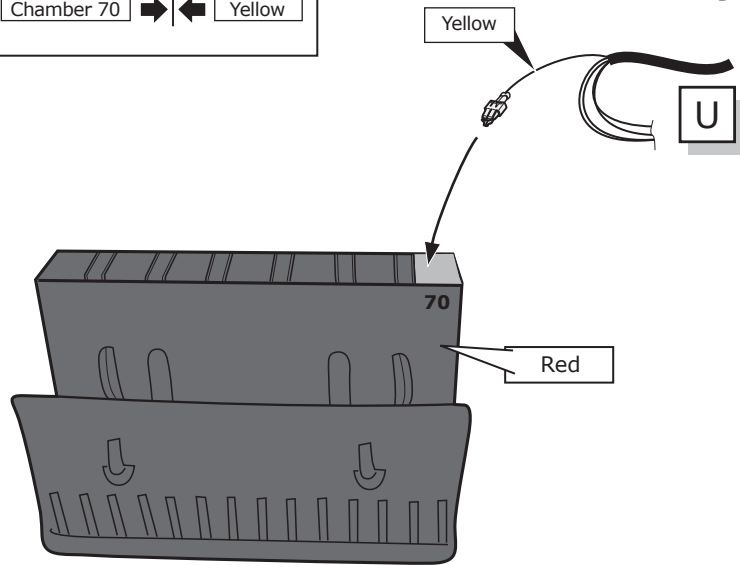

Close secondary lock!

1

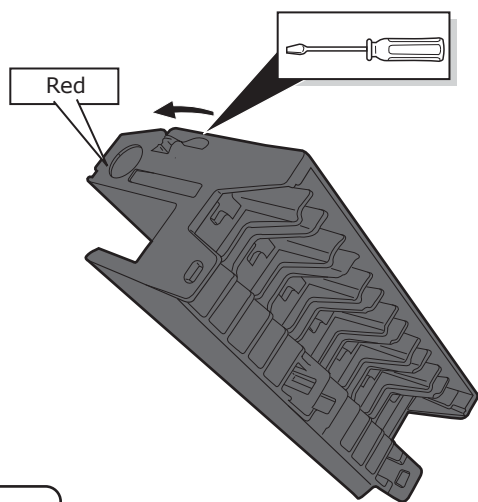

29

2

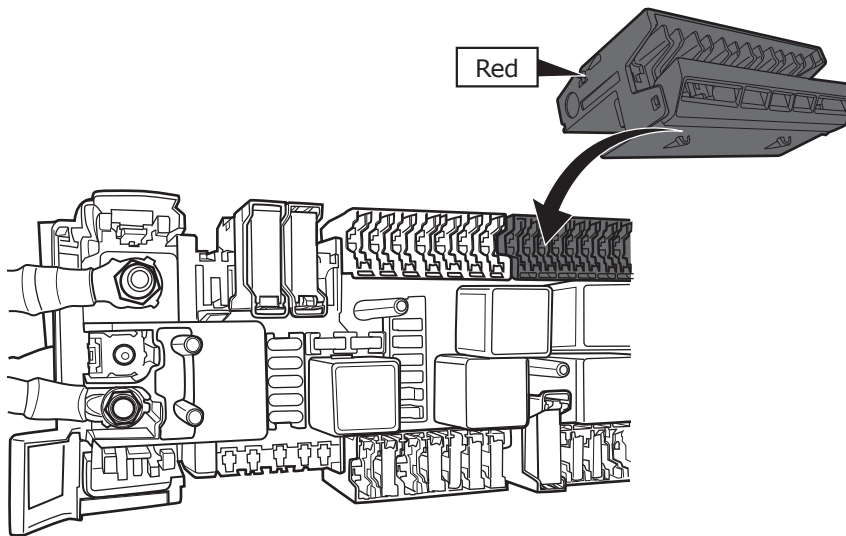

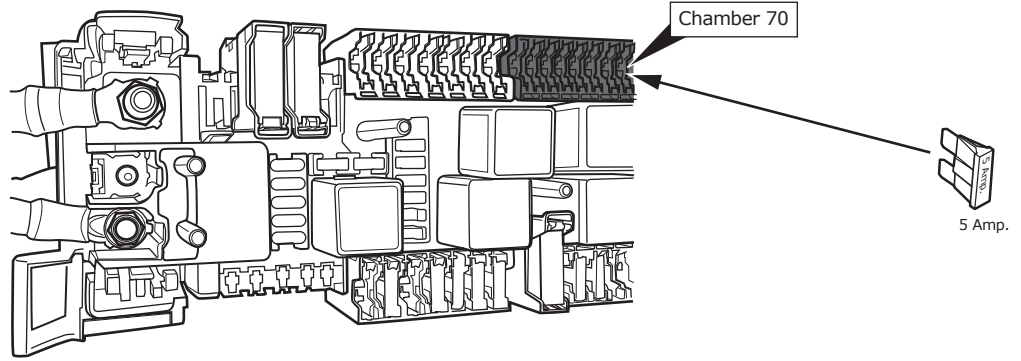
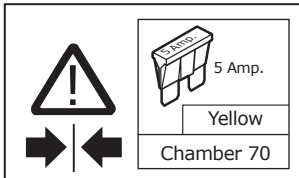

30

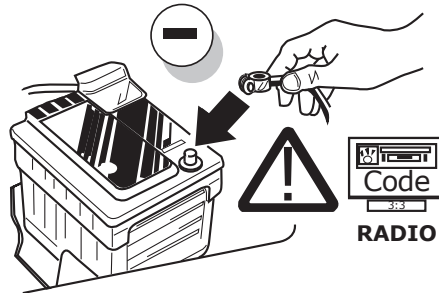

31

Optional



Trailer Simulator for 7- and 13-pin Sockets

32

Set up trailer operation

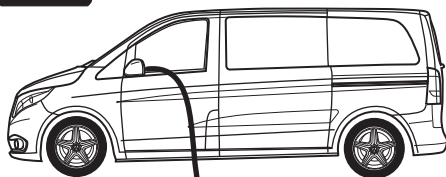

The activation of the trailer functions must be carried out as follows:

Step 1:

- Supplement optional extras via vehicle documentation (VeDoc):
- Add optional extras code Q50 (detachable trailer coupling ball)
 - Remove existing optional extras code E57 (electrics for trailer socket)

Step 2:

1. Connect STAR DIAGNOSIS to car
2. Start program
3. Click "Controllers View"
4. Click "EZS" (Ignition)
5. Click "Adjust"
6. On the left side: click Configuration SCN encoding
7. Go online a wait a few seconds
8. Click "CI" (combined instrument).
9. Click "Adjust"
10. On the left side: click Configuration SCN encoding
11. Go online a wait a few seconds
12. Conclude the diagnostic system

33

Functional test

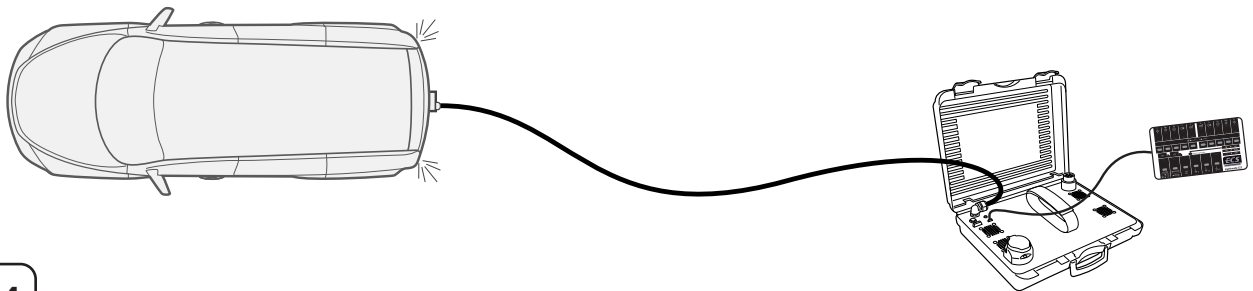
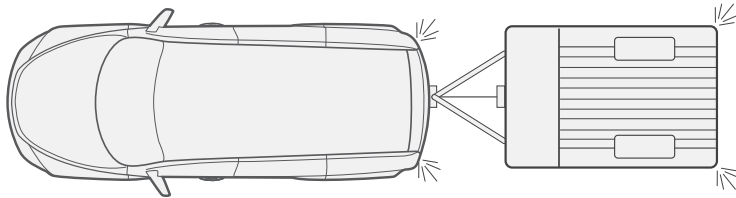
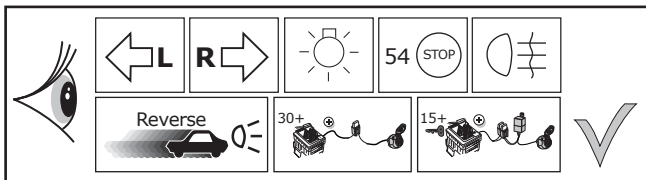

34

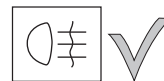
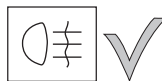
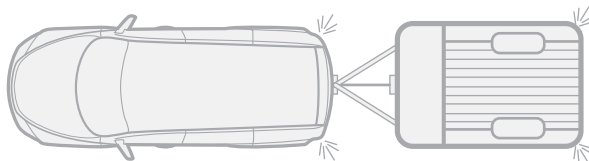

35

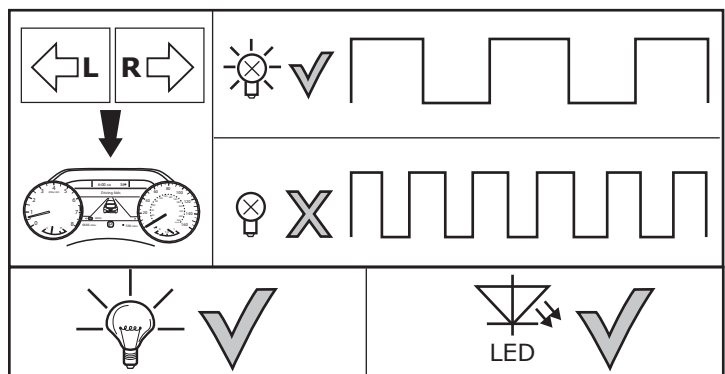
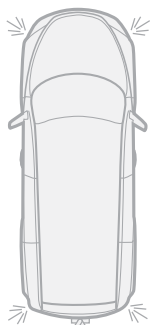

36



Option 1

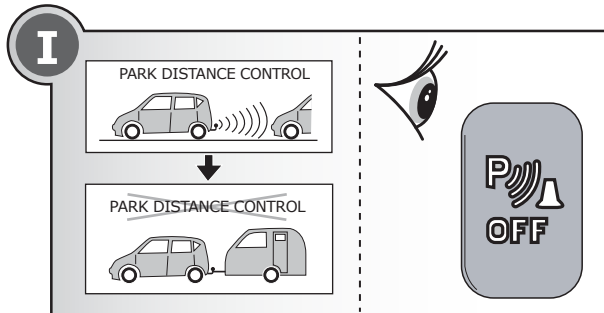
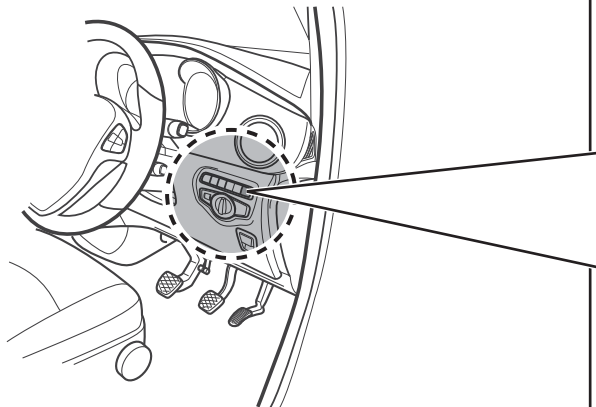

Page 17 - 18

37

Option 2

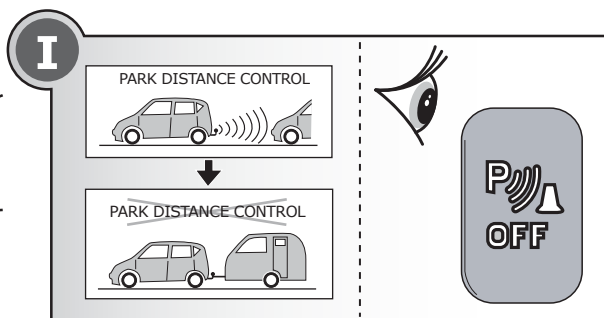
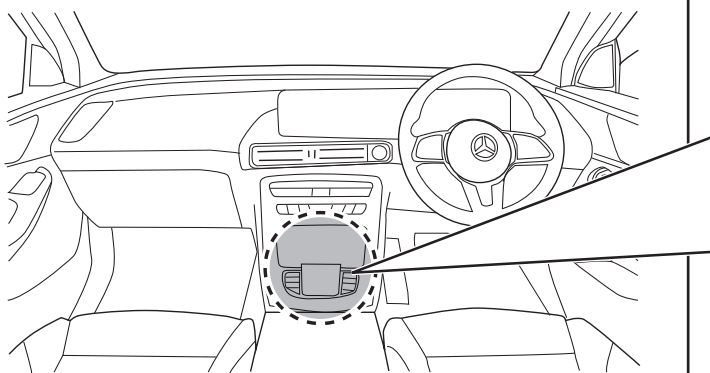

38

Optional

Adapter socket

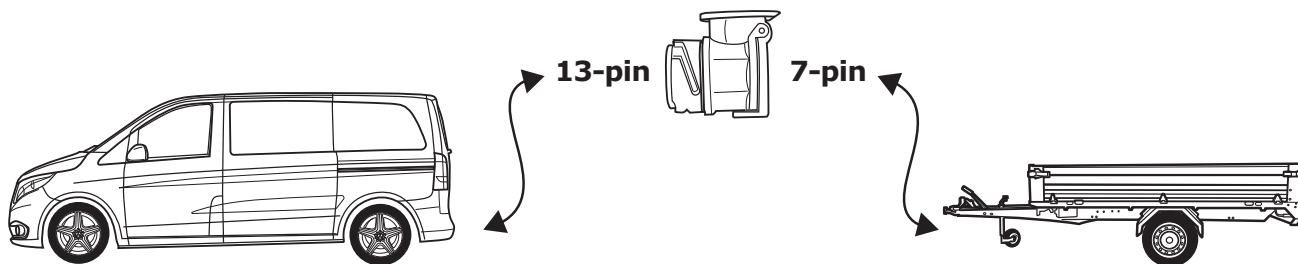

39

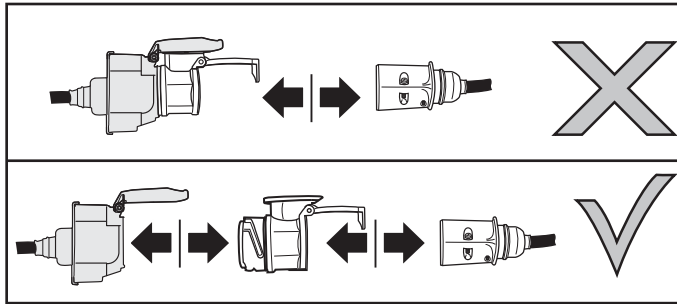
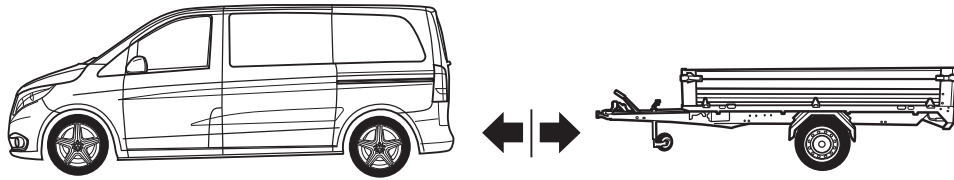

40

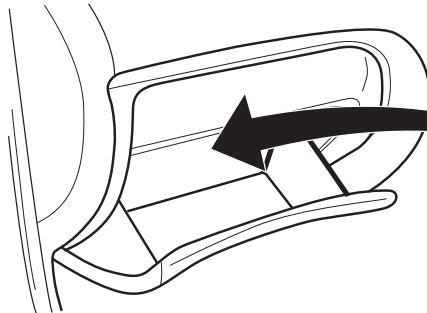

41

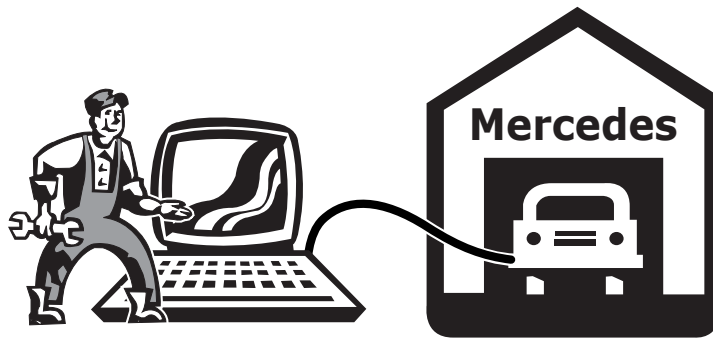

(DE)

(GB)

(FR)

Die Aktivierung der Anhängerfunktionen muss wie folgt durchgeführt werden:

1. Computer mit Auto verbinden
 2. Programm starten
 3. Klicke auf „Sonderfunktionen“
 4. Klicke auf "Eingabe bei Nachrüstungen oder Umbauten"
 5. Gebe Benutzername und Passwort ein
 6. Schreibe Q50 beim oberen (+) Feld und E57 beim unteren (-) Feld ein
 7. Akzeptiere und beende das Programm.
 8. Starte Programm erneut
 9. Klicke auf „Steuergeräte Ansicht“
 10. Verbaute Steuergeräte wie folgt programmieren:
 - a. Klicke z.B. auf „E^{ZS}“ (Elektronisches Zündschloss)
 - b. Klicke auf „Anpassung“
 - c. Auf der linken Seite: Klicke auf Aktualisierung SCN-Codierung
 - d. Gehe online und warte ein paar Sekunden
 11. Vorgang mit allen unten aufgeführten Steuergeräten durchführen:
 - „E^{ZS}“ (Elektronisches Zündschloss)
 - „S^{AM}“ (Signalerfass- und Ansteuermodul)
 - „Kombiinstrument“
 - „Headunit/Audio 20“
 - „E^{SP}“ (Elektronisches Stabilitätsprogramm)
- Wenn verbaut:
- „Parksystem“
 - „360°-Kamera“

▶ Ende der Codierung

The activation of the trailer functions has to be carried as follows:

1. Connect computer to car
 2. Start program
 3. Click "Special functions"
 4. Click "Input for retrofits or conversions"
 5. Enter you user name and password
 6. Write Q50 in the upper (+) field and E57 in the lower (-) field
 7. Accept and close the program.
 8. Start the program again
 9. Click "Controllers View"
 10. code installed control units as follows:
 - a. Click e.g. "E^{ZS}" (Ignition)
 - b. Click "Adjust"
 - c. On the left side: click updating SCN encoding
 - d. Go online a wait a few seconds
 11. Perform the operation with all the control units listed below:
 - "E^{ZS}" (Ignition)
 - "S^{AM}" (Signal detection- and control modul)
 - "combined instrument"
 - "headunit/Audio 20"
 - "E^{SP}" (Electronic Stability Program)
- if fitted:
- "Parksystem"
 - "360° camera"

▶ Coding finished

L'activation des fonctions de la remorque doit être effectuée comme suit:

1. Relier l'ordinateur à la voiture
 2. Démarrer le programme
 3. Cliquez sur «Fonctions spéciales»
 4. Cliquez sur «Saisie pour rééquipement ou transformation»
 5. Saisissez le nom d'utilisateur et le mot de passe
 6. Inscrivez Q50 dans la zone(+) en haut et E57 dans la zone (-) en bas
 7. Acceptez et quittez le programme
 8. Redémarrez le programme
 9. Cliquez sur «Vue appareils de commande»
 10. Programmez des appareils de commande montés comme suit:
 - a. Cliquez p. ex. sur «E^{ZS}» (Allumage)
 - b. Cliquez sur «Adaptation»
 - c. Sur le côté gauche: Cliquez sur actualisation SCN Codage
 - d. Rendez-vous en ligne et attendez quelques secondes
 11. Effectuer la procédure avec toutes les unités de commande dans la liste ci-dessous:
 - «E^{ZS}» (Allumage)
 - «S^{AM}» (Module de Commande)
 - «instrument combiné»
 - «headunit/Audio 20»
 - "E^{SP}" (régulation du comportement dynamique)
- si installé:
- «Système de stationnement»
 - «Caméra panoramique»

▶ Fin de codage

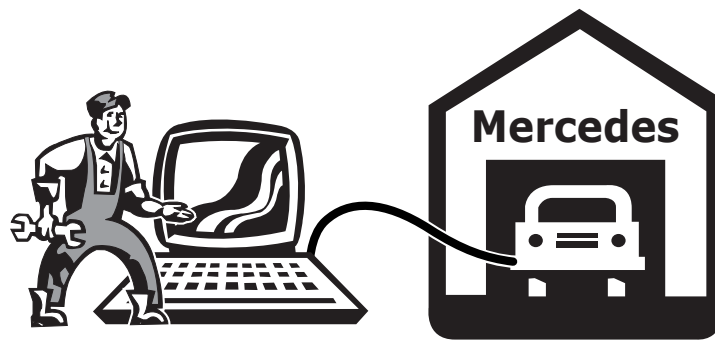

(IT)

(ES)

(NL)

L'attivazione di rimorchio funzionisi deve eseguire come segue:

1. Collegare il computer con l'auto
 2. Avviare il programma
 3. Cliccare su „Funzioni speciali“
 4. Cliccare su "Immissione in caso di optional supplementari o modifiche"
 5. Digitare il nome utente e la password
 6. Digitare Q50 nel campo superiore (+) e E57 nel campo inferiore (-)
 7. Accettare e chiudere il programma.
 8. Riavviare il programma
 9. Cliccare su „Vista Comando centralina“
10. codice unità di controllo installato come segue
- a. Cliccare p.es. „EZS“ (Blocco di accensione)
 - b. Cliccare su „Adattamento“
 - c. Sul lato sinistro: cliccare su attualizzazione SCN Codifica
 - d. Collegarsi online e aspettare alcuni secondi
11. Eseguire la procedura con tutte le centraline di seguito elencati:
- „EZS“ (Blocco di accensione)
 - „SAM“ (Modulo di controllo)
 - „strumenta combinato“
 - „headunit/Audio 20“
 - „EZS“ (Electronic Stability Program)
- se installato:
- „Sistema di parcheggio“
 - „Telecamera a 360°“

► Fine della codifica

La activación del funciones de remolque deberá llevarse a cabo de la siguiente manera:

1. Conectar el ordenador con el coche
 2. Iniciar el programa
 3. Hacer clic en "Funciones especiales"
 4. Hacer clic en "Entradas en caso de reequipamientos o modificaciones"
 5. Introducir el nombre de usuario y la contraseña
 6. Introducir Q50 en la casilla superior (+) e E57 en la casilla inferior (-)
 7. Aceptar la entrada y finalizar el programa.
 8. Volver a iniciar el programa
 9. Hacer clic en "Ver reguladores"
10. código instalado unidades de control de la siguiente
- a. Hacer clic por ejemplo en "EZS" (Ignición)
 - b. Hacer clic en "Adaptación"
 - c. En el lado izquierdo: Hacer clic en actualización SCN Codificación
 - d. Conectarse en línea y esperar un par de segundos
11. Realice el procedimiento con todas las unidades de control que se indican a continuación:
- "EZS" (Ignición)
 - "SAM" (Módulo de control)
 - "instrumento combinado"
 - "headunit/Audio 20"
 - "ESP" (programa electrónico de estabilidad)
- si está instalado:
- "Sistema de estacionamiento"
 - "Cámara de 360°"

► Fin de la codificación

De activering van de trailer-functies moet als volgt worden uitgevoerd:

1. Computer met auto verbinden
 2. Programma starten
 3. Klik op „Speciale functies“
 4. Klik op "Invoer bij achteraf toegevoegde onderdelen of modificaties"
 5. Voer gebruikersnaam en wachtwoord in
 6. Schrijf Q50 in het bovenste (+) veld en E57 in het onderste (-) veld
 7. Accepteer en beëindig het programma.
 8. Start programma opnieuw
 9. Klik op „Bekijk besturingsapparaten“
10. code geïnstalleerd besturingsapparaten als volgt
- a. Klik bijvoorbeeld op „EZS“ (Ignition)
 - b. Klik op „Aanpassing“
 - c. Aan de linkerkant: klik op update SCN-codering
 - d. Ga online en wacht een paar seconden
11. Voer de proces met alle hieronder genoemde besturingsapparaten:
- „EZS“ (Ignition)
 - „SAM“ (Signal detection- and control modul)
 - „kombi-instrument“
 - „headunit/Audio 20“
 - „ESP“ (elektronisch stabiliteitsprogramma)
- indien geïnstalleerd:
- „Parking system“
 - „360°-camera“

► Uiteinde van het coderende

SOCKET CONNECTION

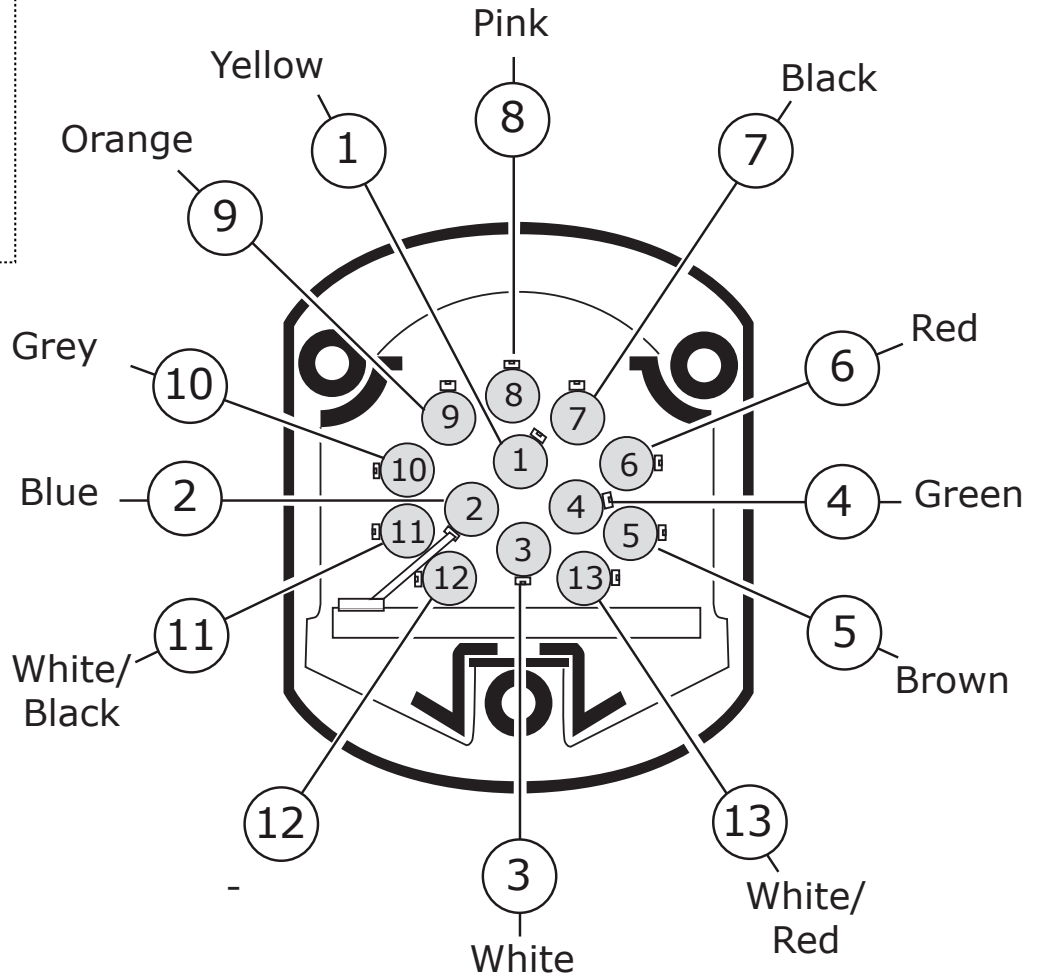
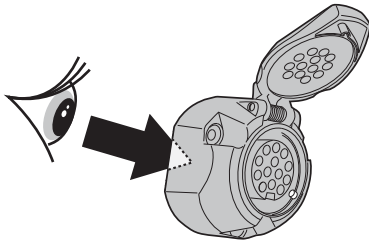

(DE) Anschluss Steckdose	(ES) Conexión de la caja de enchufe	(CZ) Objímkový konektor	(GR) Υποδοχή σύνδεσης
(FR) Connection de la prise	(IT) Allaccio zoccolo	(DK) Stikdåse forbindelse	(NO) Tilkobling koblingsboks
(NL) Contactdoos aansluiting	(SE) Anslutning kontaktdosa	(FI) Pistorasia liitäntä	(PL) Połączenie przez gniazdo
(GB) Socket connection			

DIN/ISO 11446													
	1/L	2	3/31	4/R	5/58-R	6/54	7/58-L	8	9	10	11	12	13
Pmax	21W	21W		21W	42W	3x21W	42W	21W	240W	180W			
	Yellow	Blue	White	Green	Brown	Red	Black	Pink	Orange	Grey	White/Black	-	White/Red

	BK	BN	BU	GY	GN	WH	YE	OG	PE	PI	RD
(DE)	Schwarz	Braun	Blau	Grau	Grün	Weiß	Gelb	Orange	Violett	Rosa	Rot
(FR)	Noir	Marron	Blue	Gris	Vert	Blanc	Jaune	Orange	Violet	Rose	Rouge
(NL)	Zwart	Bruin	Blauw	Grijs	Groen	Wit	Geel	Oranje	Paars	Roze	Rood
(GB)	Black	Brown	Blue	Grey	Green	White	Yellow	Orange	Purple	Pink	Red
(ES)	Negro	Marrón	Azul	Gris	Verde	Blanco	Amarillo	Naranja	Morado	Rosa	Rojo
(IT)	Nero	Marrone	Blu	Grigio	Verde	Bianco	Giallo	Arancione	Viola	Rosa	Rosso
(SE)	Svart	Brun	Blå	Grå	Grön	Vit	Gul	Orange	Lila	Rosa	Röd
(CZ)	Černá	Hnědá	Modrá	Šedá	Zelená	Bílá	Žlutá	Oranžová	Fialová	Růžová	Červená
(DK)	Sort	Brun	Blå	Grå	Grøn	Hvid	Gul	Orange	Lilla	Pink	Rød
(FI)	Musta	Ruskea	Sininen	Harmaa	Vihreä	Valkoinen	Keltainen	Oranssi	Purppura	Vaaleanpunainen	Punainen
(GR)	Μαύρο	Καφέ	Μπλε	Γκρι	Πράσινο	Λευκό	Κίτρινο	Πορτοκαλί	Μοβ	Ροζ	Κόκκινο
(NO)	Svart	Brun	Blå	Grå	Grønn	Hvit	Gul	Oransje	Lilla	Rosa	Rød
(PL)	Czarny	Brazowy	Niebieski	Szary	Zielony	Biały	Żółty	Pomarańczowy	Purpurowy	Różowy	Czerwony